

Pump Specification

commercialseries

LSS500-Series

5 hp Open 2 Vane Sewage Pumps

2-1/2" Solids Handling

3" Horizontal or Vertical Discharge

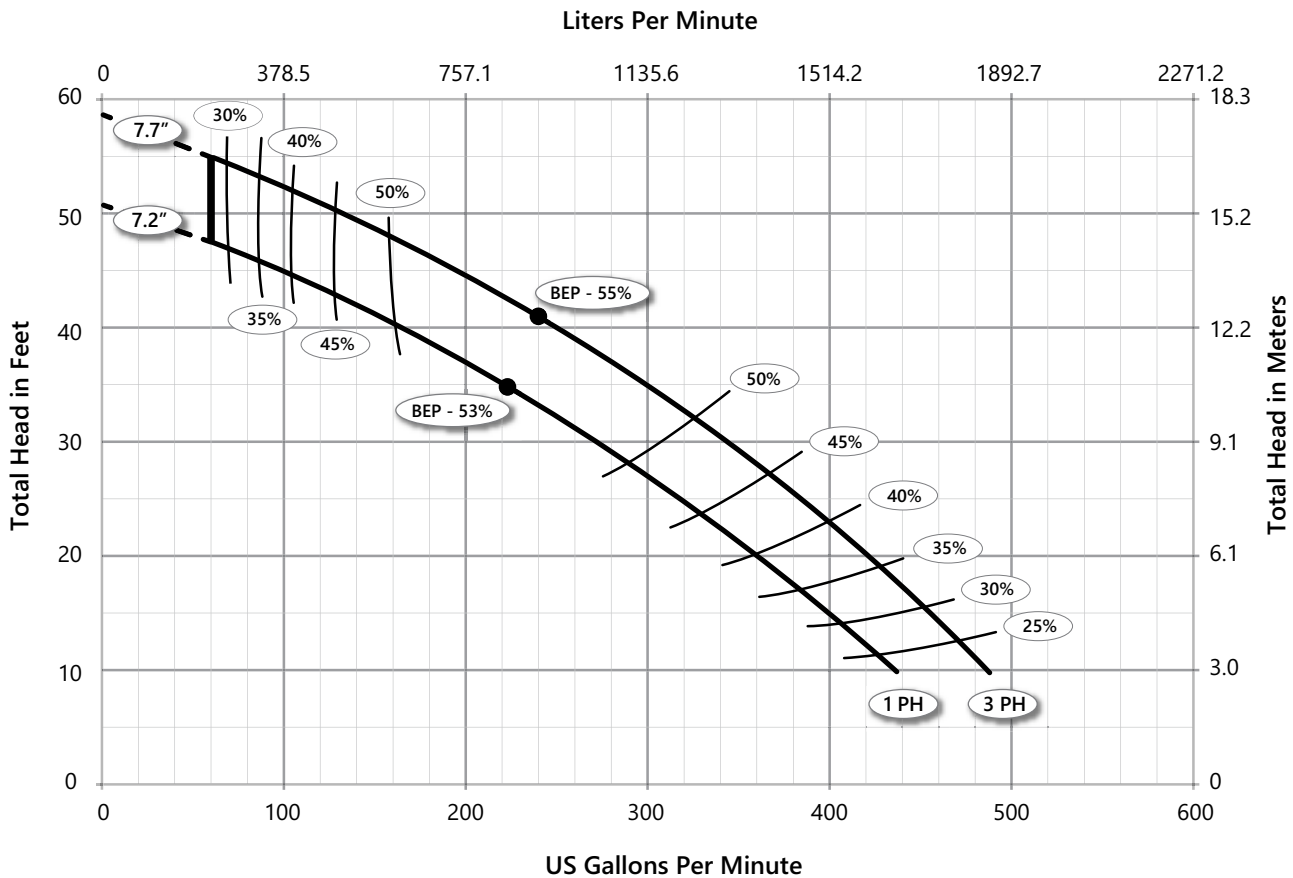
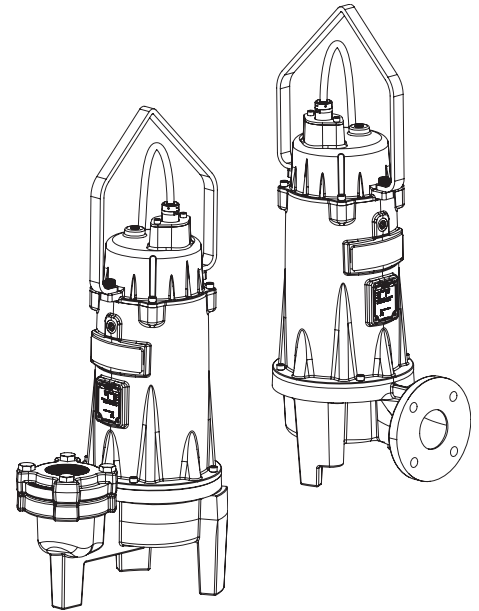

Stated efficiency values are Hydraulic efficiency. Wire-to-Water efficiency information is available upon request.

Pumps must operate within the proper range shown on the performance chart. It is the responsibility of the end user to ensure this requirement is met. Pumps operating outside the recommended range are prone to damage, excessive vibration, cavitation, poor efficiency, and will exceed nameplate amperage.

LSS500-Series Dimensional Data - Horizontal Discharge

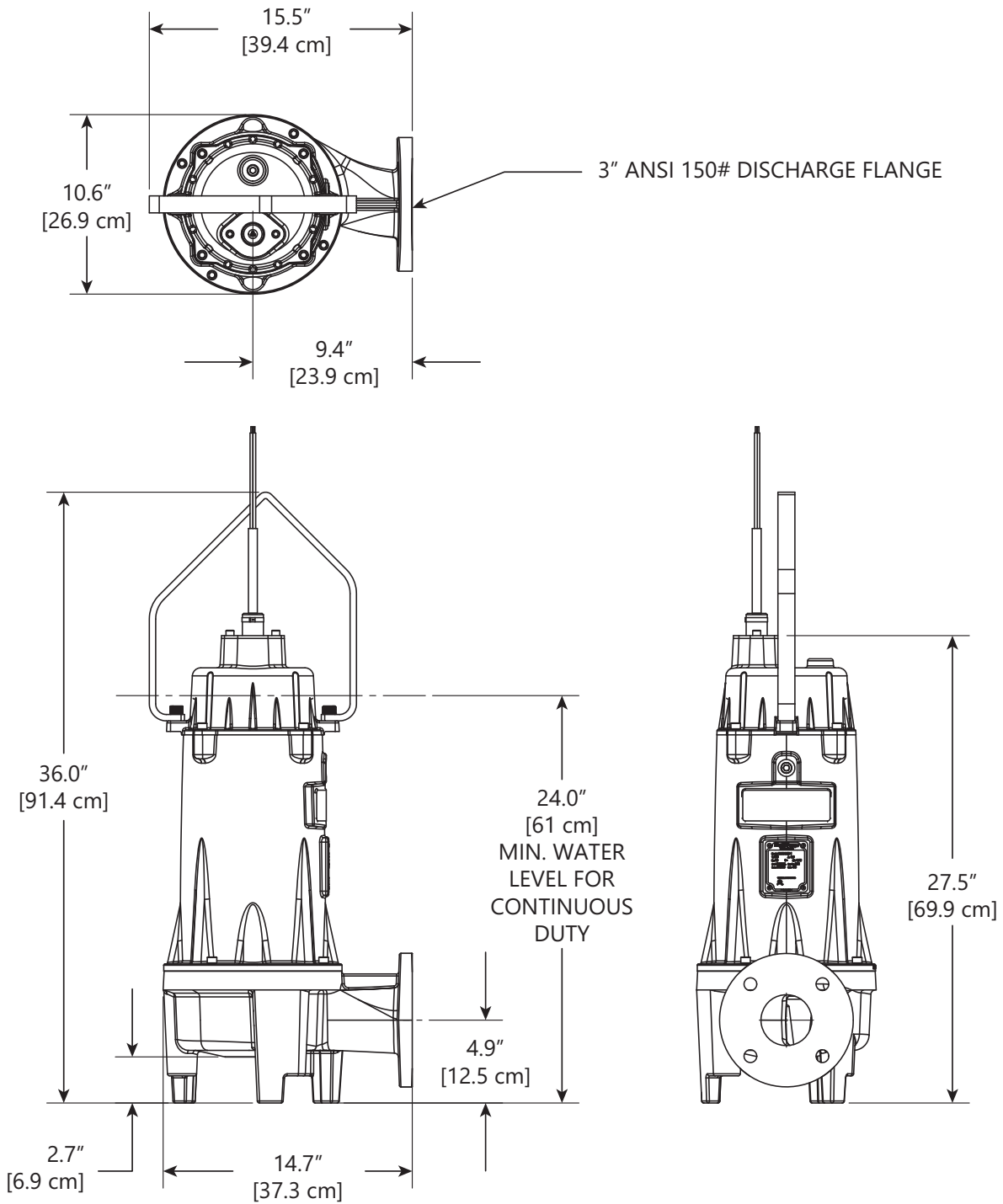

LSS500-Series Dimensional Data - Vertical Discharge

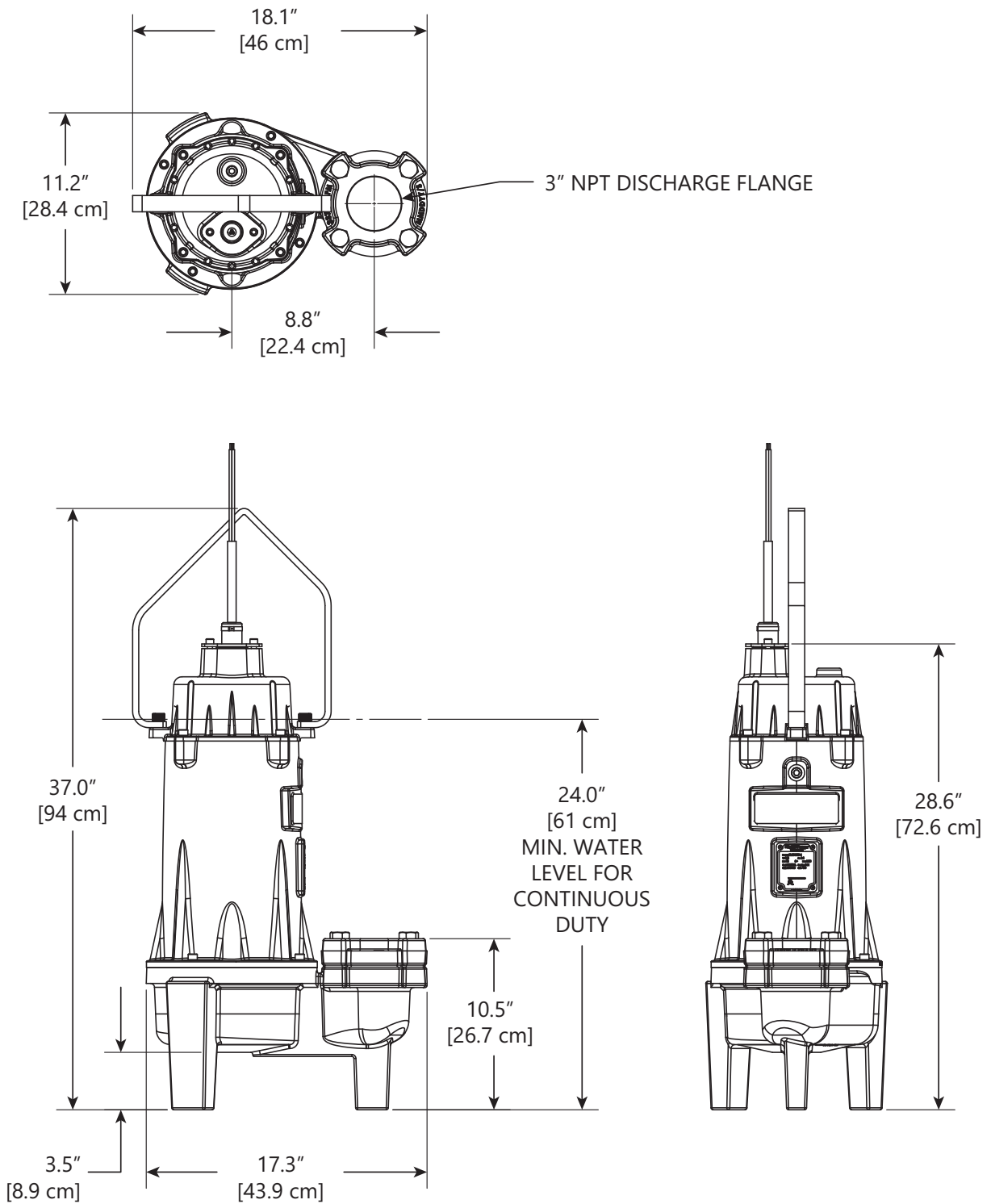

LSS500-Series Electrical Data

HORIZONTAL DISCHARGE										
MODEL	HP	VOLTAGE ¹	PHASE	FULL LOAD AMPS	LOCKED ROTOR AMPS	MAX KW INPUT	SERVICE FACTOR	POWER FACTOR	KVA CODE	CORD LENGTH OPTIONS [FT]
LSS502-3	5	200/230	1	22.5	73.7	4.9	1	0.96	B	35
LSS502-3-C ²	5	200/230	1	22.5	73.7	4.9	1	0.96	B	35
LSS502-5	5	200/230	1	22.5	73.7	4.9	1	0.96	B	50
LSS502-5-C ²	5	200/230	1	22.5	73.7	4.9	1	0.96	B	50
LSS502-1	5	200/230	1	22.5	73.7	4.9	1	0.96	B	100
LSS502-1-C ²	5	200/230	1	22.5	73.7	4.9	1	0.96	B	100
LSS503-3	5	200/230	3	19	36.1	6.3	1	0.82	H	35
LSS503-5	5	200/230	3	19	36.1	6.3	1	0.82	H	50
LSS503-1	5	200/230	3	19	36.1	6.3	1	0.82	H	100
LSS504-3	5	460	3	9	18.1	6.2	1	0.80	H	35
LSS504-5	5	460	3	9	18.1	6.2	1	0.80	H	50
LSS504-1	5	460	3	9	18.1	6.2	1	0.80	H	100
LSS505-3	5	575	3	7.4	14.6	6.4	1	0.80	H	35
LSS505-5	5	575	3	7.4	14.6	6.4	1	0.80	H	50
LSS505-1	5	575	3	7.4	14.6	6.4	1	0.80	H	100
VERTICAL DISCHARGE										
MODEL	HP	VOLTAGE ¹	PHASE	FULL LOAD AMPS	LOCKED ROTOR AMPS	MAX KW INPUT	SERVICE FACTOR	POWER FACTOR	KVA CODE	CORD LENGTH OPTIONS [FT]
LSS502V-3	5	200/230	1	22.5	73.7	4.9	1	0.96	B	35
LSS502V-3-C ²	5	200/230	1	22.5	73.7	4.9	1	0.96	B	35
LSS502V-5	5	200/230	1	22.5	73.7	4.9	1	0.96	B	50
LSS502V-5-C ²	5	200/230	1	22.5	73.7	4.9	1	0.96	B	50
LSS502V-1	5	200/230	1	22.5	73.7	4.9	1	0.96	B	100

VERTICAL DISCHARGE										
MODEL	HP	VOLTAGE ¹	PHASE	FULL LOAD AMPS	LOCKED ROTOR AMPS	MAX KW INPUT	SERVICE FACTOR	POWER FACTOR	KVA CODE	CORD LENGTH OPTIONS [FT]
LSS502V-1-C ²	5	200/230	1	22.5	73.7	4.9	1	0.96	B	100
LSS503V-3	5	200/230	3	19	36.1	6.3	1	0.82	H	35
LSS503V-5	5	200/230	3	19	36.1	6.3	1	0.82	H	50
LSS503V-1	5	200/230	3	19	36.1	6.3	1	0.82	H	100
LSS504V-3	5	460	3	9	18.1	6.2	1	0.80	H	35
LSS504V-5	5	460	3	9	18.1	6.2	1	0.80	H	50
LSS504V-1	5	460	3	9	18.1	6.2	1	0.80	H	100
LSS505V-3	5	575	3	7.4	14.6	6.4	1	0.80	H	35
LSS505V-5	5	575	3	7.4	14.6	6.4	1	0.80	H	50
LSS505V-1	5	575	3	7.4	14.6	6.4	1	0.80	H	100

1. System voltages: 208 and 240 volts with utilization voltages: 200 and 230 volts
2. External capacitor models require 1-phase cap kit K001747

LSS500-Series Control Panel Information

PUMP MODEL (HORIZONTAL & VERTICAL MODELS)	CONTROL PANEL MODEL		
	3 FLOAT SIMPLEX	3 FLOAT DUPLEX	4 FLOAT DUPLEX
LSS502	SXK24=3	AE24K=3	AE24K=4
LSS502-C ¹	SX24KC1=3	AE24KC2=3	AE24KC2=4
LSS503	SX34=3-621	AE34=3-621	AE34=4-621
LSS504	SX34=3-511	AE34=3-511	AE34=4-511
LSS505	SX54=3-405	AE54=3-405	AE54=4-405

1. External capacitor models require 1-phase cap kit K001747

LSS500-Series Technical Data

MOTOR INSULATION CLASS	F	
MAX STATOR TEMP	170°C (1-PHASE THERMAL PROTECTOR)	
IMPELLER TYPE	OPEN 2 VANE	
IMPELLER MATERIAL	CLASS 30 CAST IRON	
IMPELLER DIAMETER	1-PHASE - 7.2 IN	3-PHASE - 7.7 IN
SHUT-OFF HEAD	1-PHASE - 51 FT	3-PHASE - 59 FT
MIN HEAD	10 FT	
MAX FLOW @ MIN HEAD	1-PHASE - 435 GPM	3-PHASE - 485 GPM
QUICK-CONNECT CORD	STANDARD	
POWER CORD TYPE	SOOW	
SEAL MATERIAL	SILICON CARBIDE / SILICON CARBIDE	
MAX WATER TEMP FOR CONTINUOUS DUTY	40°C / 104°F	
MIN FLUID LEVEL FOR CONTINUOUS OPERATION	24 IN (MOTOR HOUSING FULLY SUBMERGED)	
FLUID pH RANGE	4-10	
SHAFT MATERIAL	303 STAINLESS EXTENSION	
FASTENER MATERIAL	316 STAINLESS STEEL	
O-RING ELASTOMERS	BUNA-N	
UPPER BEARING	SINGLE ROW DEEP GROOVE RADIAL CONTACT	
LOWER BEARING	SINGLE ROW DEEP GROOVE RADIAL CONTACT	
OIL TYPE	ISO VG 10 TURBINE OIL	
MAX SUBMERSION DEPTH	75 FT	
SOLIDS HANDLING	2-1/2 IN	
DISCHARGE (STANDARD)	HORIZONTAL, 3 IN 150# ANSI	
DISCHARGE (OPTIONAL)	VERTICAL, 3 IN NPT	
PROTECTIVE EXTERNAL FINISH	EPOXY POWDER COAT	
THERMAL PROTECTION	1-PHASE - HERMETICALLY SEALED THERMAL PROTECTOR	3-PHASE - OVERLOADS REQUIRED IN PANEL
VOLUTE MATERIAL	CLASS 30 CAST IRON	
WEIGHT	136 KG / 300 LBS	
CERTIFICATIONS	CSA CERTIFIED TO CSA AND UL® STANDARDS CAN/CSA C22.2 NO. 108 ANSI/UL 778	

LSS500-Series Specifications

1.01 GENERAL

The contractor shall provide labor, material, equipment, and incidentals required to provide _____ (QTY) sewage pumps as specified herein. The COMMERCIAL SERIES pump models covered in this specification are 1-phase model LSS502, and 3-phase models LSS503, LSS504, and LSS505 open 2 vane pumps. The pump furnished for this application shall be model _____ as manufactured by Liberty Pumps.

2.01 OPERATING CONDITIONS

Each LSS500-Series submersible pump shall be rated at 5 hp, _____ Volts, _____ phase, 60 Hz, 1725 RPM. The unit shall produce _____ GPM at _____ feet of total dynamic head.

The submersible pump shall be capable of handling residential and commercial sewage with 2-1/2" solids handling capability. The submersible pump shall have a shut-off head of 51 feet and a max flow of 435 GPM @ 10 feet of total dynamic head for 1-phase and a shut-off head of 59 feet and a max flow of 485 GPM @ 10 feet of total dynamic head for 3-phase.

3.01 CONSTRUCTION

Each centrifugal sewage pump shall be equal to the  Certified LSS-Series pumps as manufactured by Liberty Pumps, Bergen NY. The casting enclosing the motor shall be constructed of class 25 cast iron. The motor housing shall be oil-filled to dissipate heat. Air-filled motors shall not be considered equal since they do not properly dissipate heat from the motor. Mating parts shall be machined and sealed with a Buna-N O-ring. All fasteners exposed to the process fluid shall be stainless steel. The motor shall be protected on the top side with a sealed cast iron cord entry plate. The motor shall be protected on the lower side with a single mechanical seal. The seal shall be a two-piece mechanical seal with silicon carbide faces. The upper and lower bearings shall be sized to properly withstand radial and thrust loads produced throughout the full operating range of the pump.

4.01 POWER CORD

The submersible pump shall be supplied with 35, 50, or 100 feet of a multi-conductor cord of type SOOW. These type SOOW power cords carry a voltage rating of 600 V, a temperature rating of 90°C, have oil-resistant insulation, are water- and weather-resistant, UL listed, and CSA approved. The power cord shall be sized for the rated full load amps of the pump for continuous duty in accordance with the NEC®.

Standard Quick-connect cord shall offer quick cord replacement without the need to send the entire pump to an authorized repair facility. This shall also allow for pump maintenance without disturbing electrical boxes or control panels.

5.01 MOTOR

The motor shall be oil-filled, Class F insulated, and rated for continuous duty. Since air-filled motors are not capable of dissipating heat efficiently, they shall not be considered equal. Pumps requiring an auxiliary cooling means shall not be considered equal.

The copper stator windings shall be insulated with moisture-resistant Class F insulation materials, rated for 155°C. The maximum continuous temperature of pumped liquids shall be 40°C. The winding operating temperature at rated horsepower shall be a maximum of 140°C @ 40°C ambient.

Motor shall have thermal protector on 1-phase model LSS502 to cut power to motor in thermal overheat conditions.

6.01 BEARINGS AND SHAFT

The shaft shall be supported by two radial ball bearings. Both bearings shall be permanently lubricated by the oil that fills the motor housing. Pump designs requiring scheduled bearing maintenance shall not be considered equal.

The motor shaft extension shall be made of 303 stainless steel. The shaft shall be designed to withstand the maximum torque and radial loads present during start-up and normal operation.

7.01 SEAL

The pump shall have one shaft seal. The mechanical seal shall be a two-piece design that is easily serviceable. Shaft seal shall not require scheduled maintenance. Seal shall be silicon carbide on silicon carbide. Seal shall include stainless steel housings and Buna elastomers.

8.01 IMPELLER

The impeller shall be ASTM class 30 cast iron. The open 2 vane impeller design provides an efficient path through the impeller for solids to pass without getting caught or snagged. The impeller shall be keyed and bolted onto the motor shaft.

9.01 CONTROL PANEL

All LSS-Series pumps require a control panel. The control panel shall be equipped with circuit breakers and adjustable overload devices to protect against excess current or electrical problems. 1-phase model LSS502 shall additionally require run capacitors. External capacitor models (ending in -C) require capacitors in the control panel. The control panel shall be sized appropriately for the pump model(s) being controlled.

10.01 QUALITY CONTROL

The pump shall be manufactured in an ISO[®] 9001 certified facility. Manufactured in the USA with US and global components.

11.01 SUPPORT

The pump shall have cast iron support legs, enabling it to be a freestanding unit. The legs shall be high enough to allow solids and long, stringy debris to enter the pump inlet.

12.01 PROTECTIVE FINISH

The exterior of the casting shall be protected with corrosion-resistant baked-on epoxy powder coat.

13.01 TESTING

The pump shall have a ground continuity check and undergo a hi-pot test for electrical integrity, moisture content, and insulation defects. The motor housing shall be pressurized, and an air leak decay test performed to ensure integrity of the assembled unit. The pump shall be monitored for run voltage and current, and checked for noise or other malfunction. Certified performance testing is available upon request.

14.01 WARRANTY

Liberty Pumps, Inc. warrants that pumps of its COMMERCIAL SERIES line are free from all factory defects in material and workmanship for a period of 18 months from the date of installation or 24 months from the date of manufacture, whichever occurs first, and provided that such products are used in compliance with their intended applications as set forth in the specifications and technical manuals. The date of installation shall be determined by a completed COMMERCIAL SERIES pump start-up report and warranty registration form.